

Mögliche Antriebsanordnungen KA19 / possible drive arrangements KA19

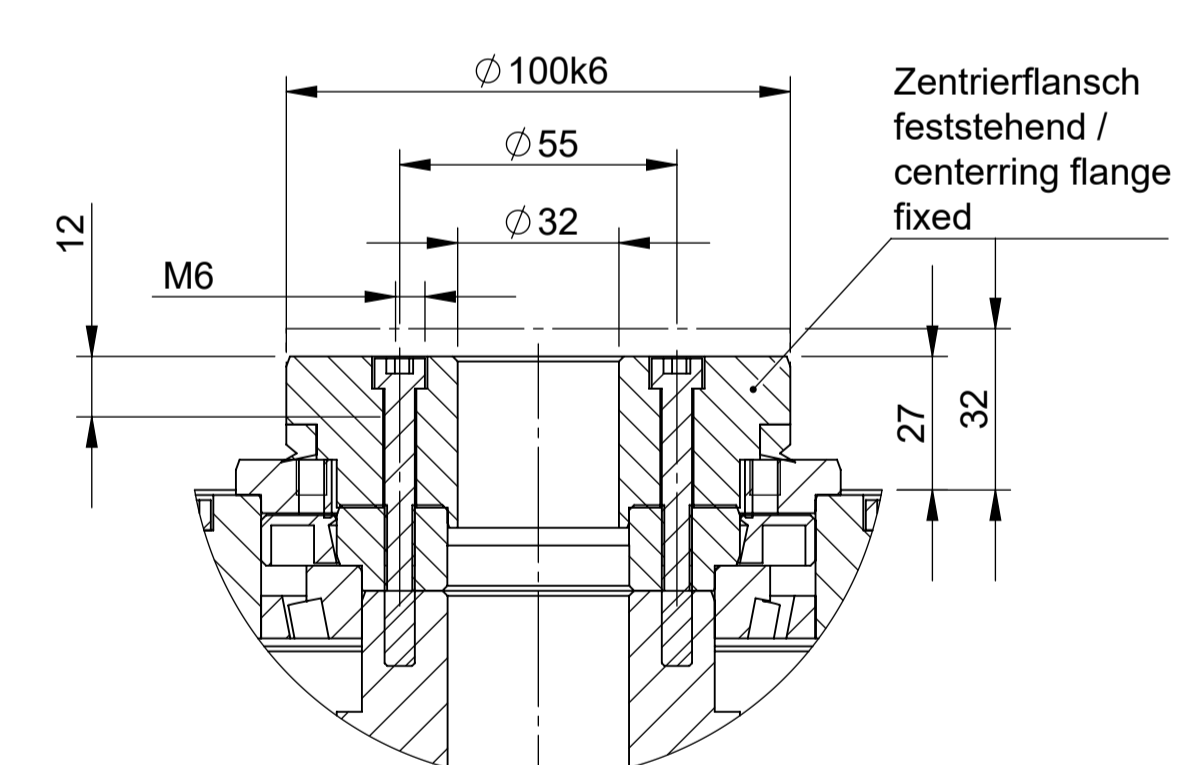
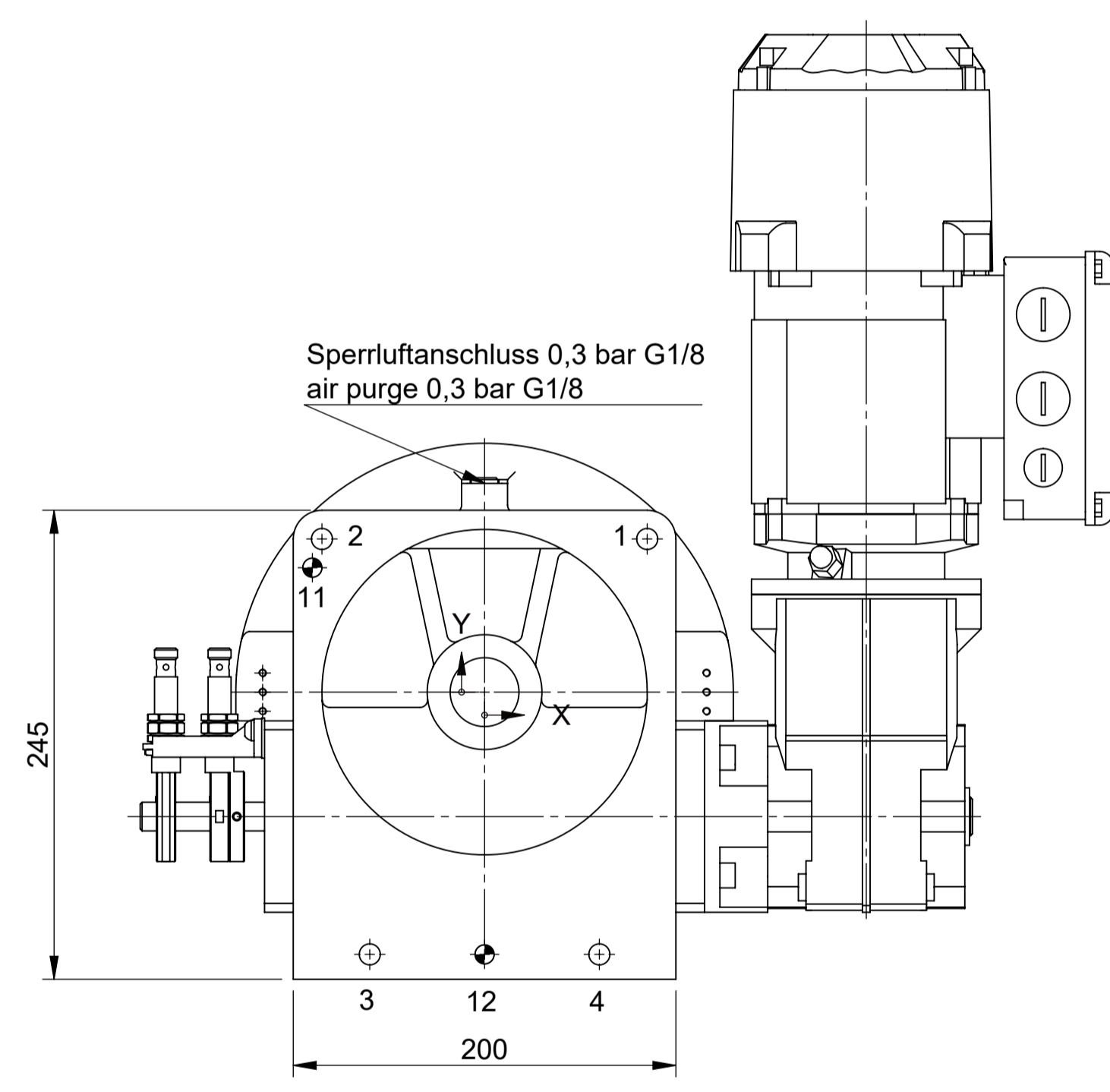
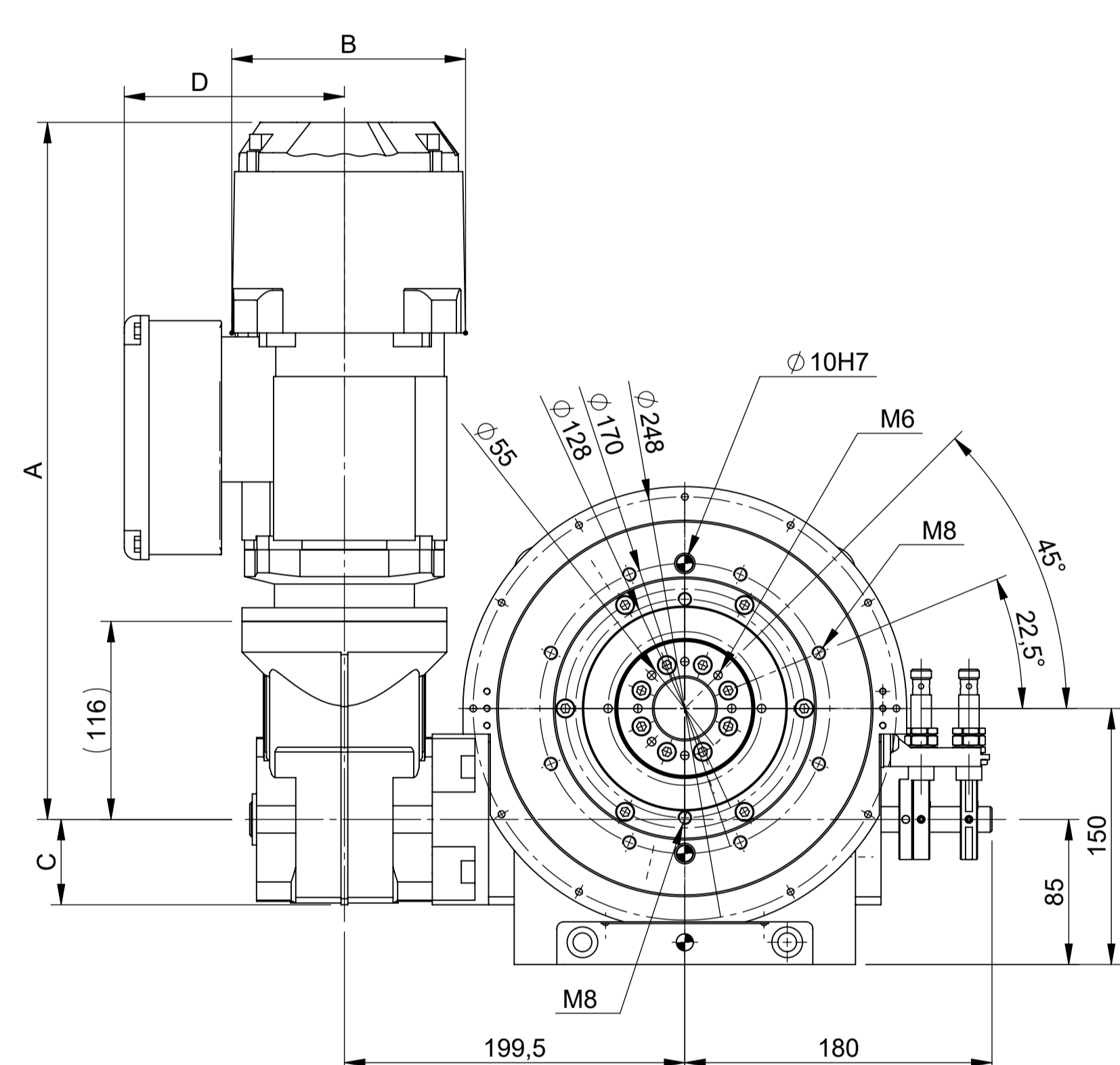
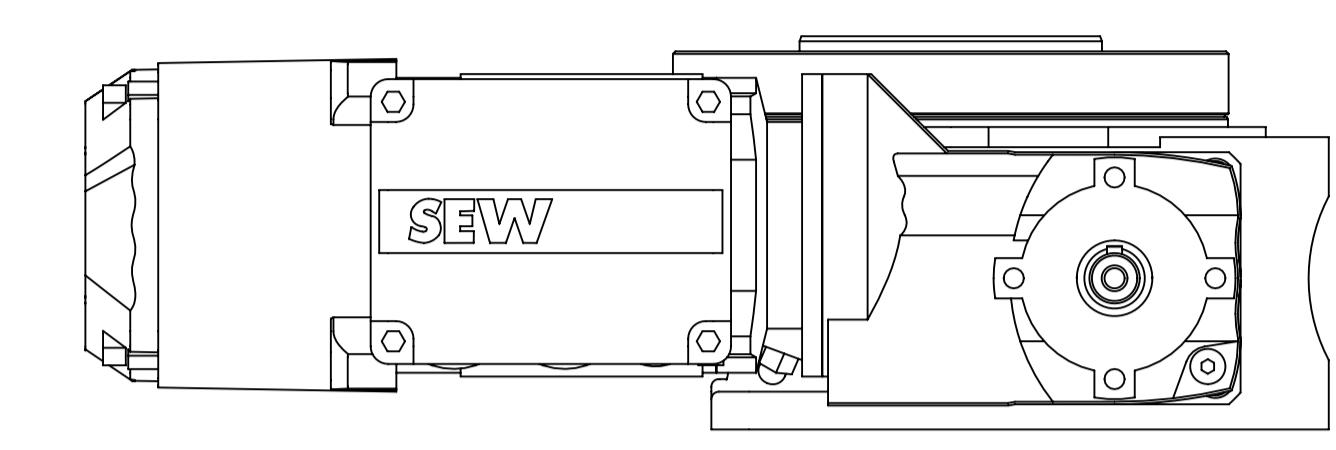
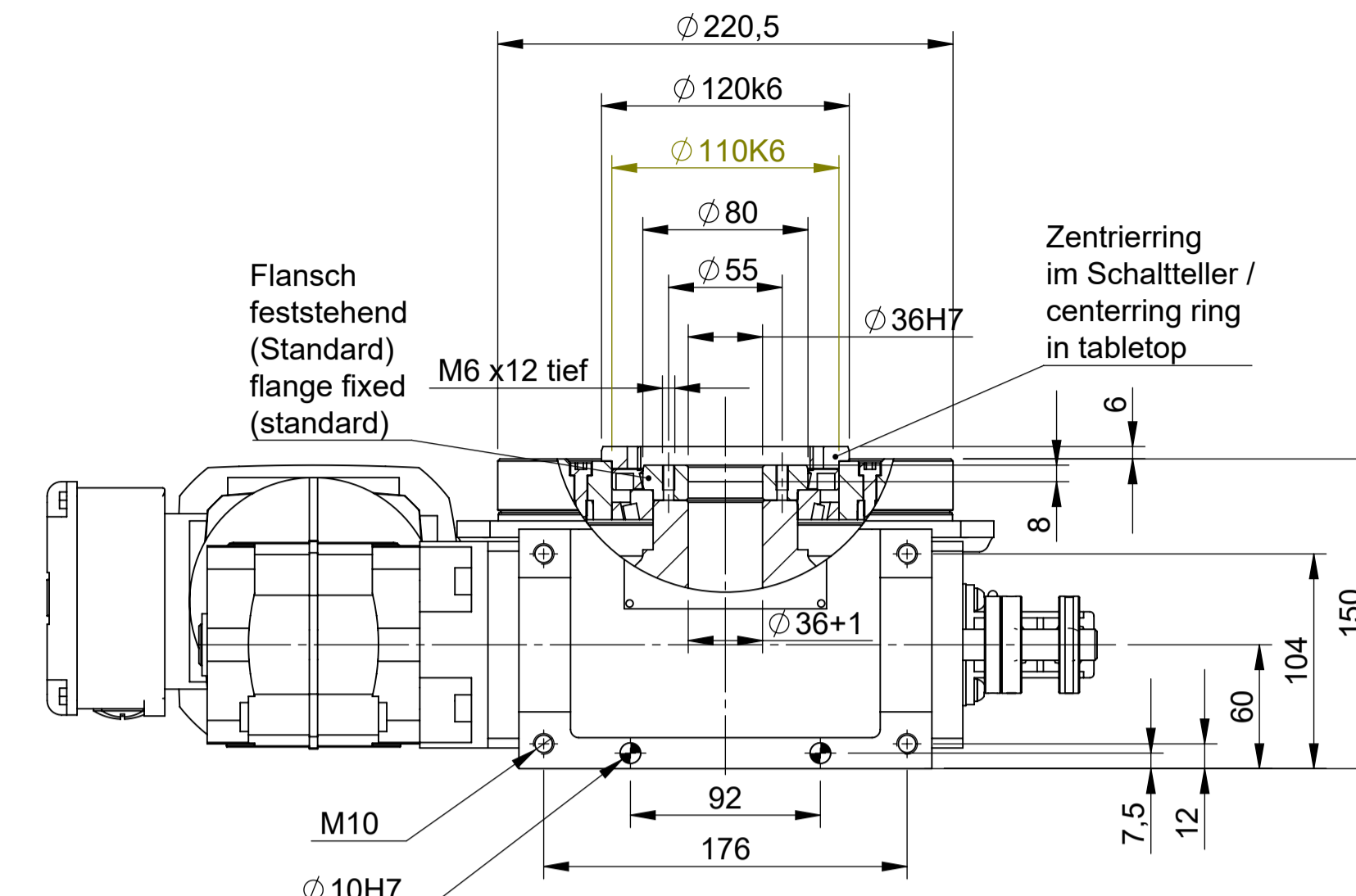
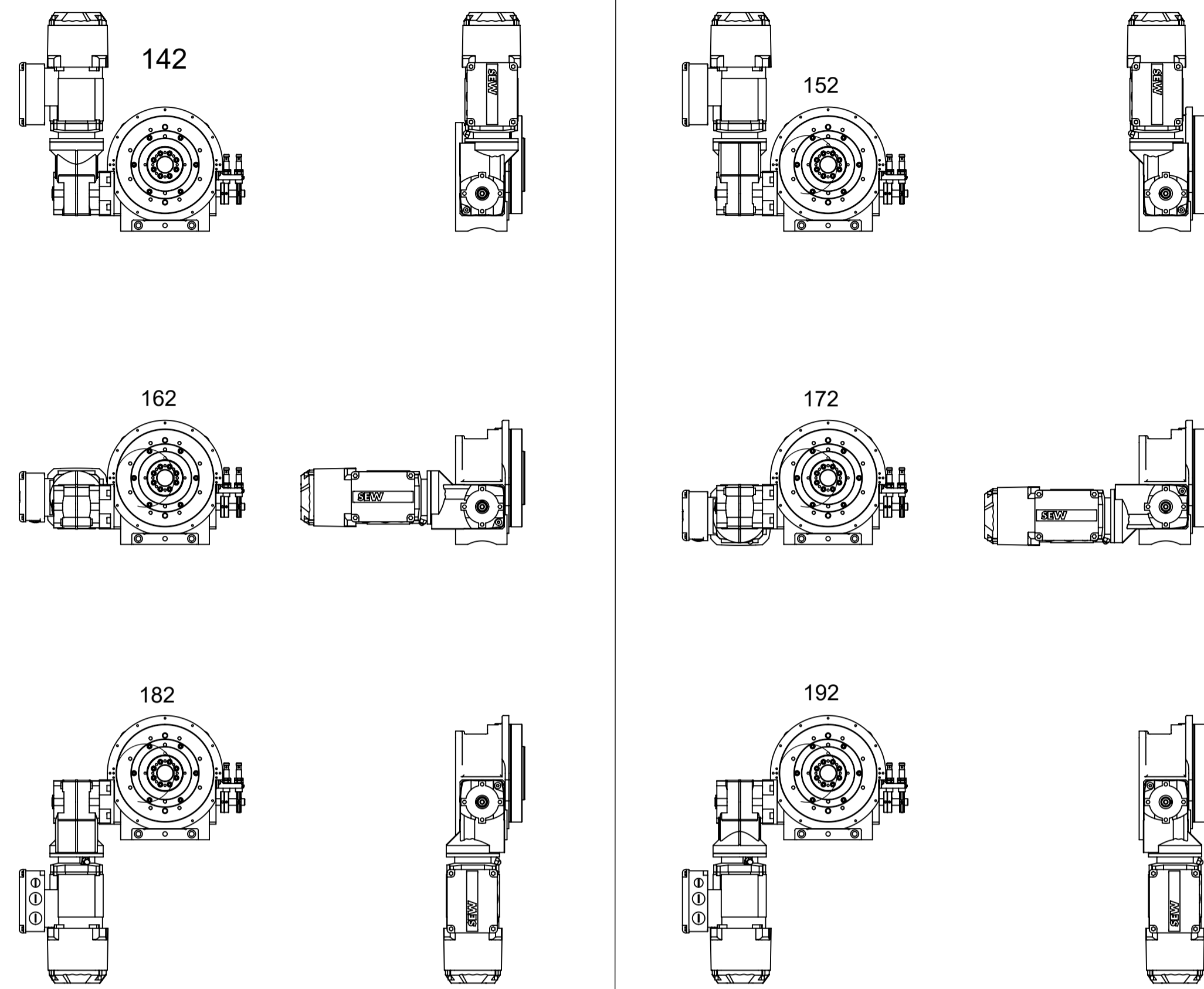

DETAIL C
MASSTAB / SCALE 2 : 3

| Motor Typ | A | B | C | D |
|-----------|-----|-----|----|-----|
| Bgr. 63 | 376 | 125 | 50 | 98 |
| Bgr. 71 | 408 | 137 | 50 | 129 |

| Pos. | X | Y | Beschreibung / Description |
|------|-----|------|---|
| 1 | 85 | 80 | TYP S - D1 $\varnothing 11$ (BT 15) - D2 $\varnothing 18$ T 2 - $\varnothing 0,2$ |
| 2 | -85 | 80 | |
| 3 | -60 | -137 | |
| 4 | 60 | -137 | |

| Pos. | X | Y | Beschreibung / Description |
|------|-----|------|--|
| 11 | -90 | 65 | TYP SD - D $\varnothing 10H7$ (BT 15,001) - $\varnothing 0,02$ |
| 12 | 0 | -137 | |

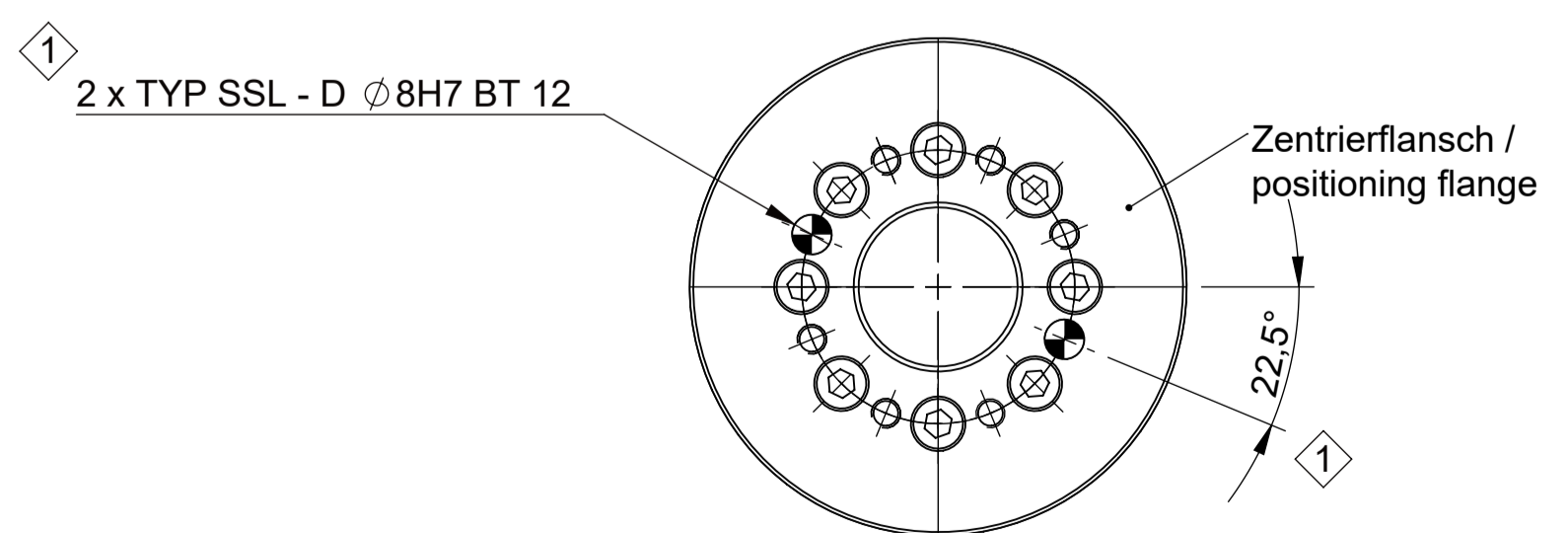

DETAIL D
MASSTAB / SCALE 2 : 3

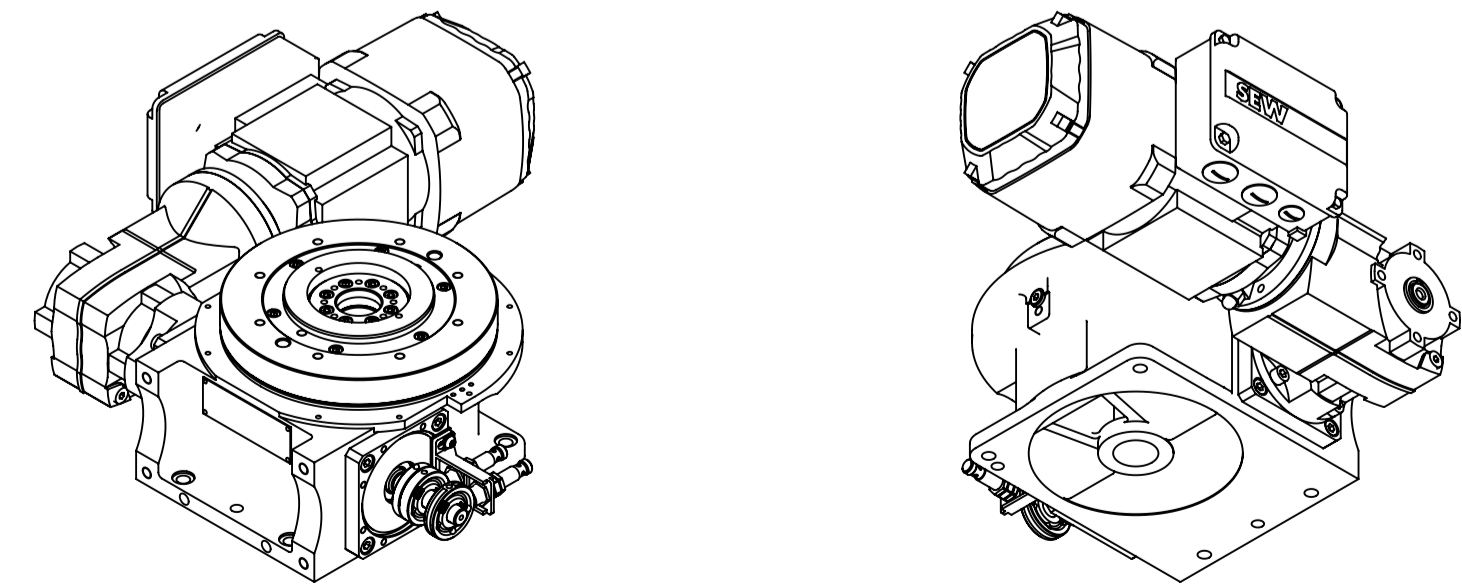

Bildliche Darstellung unverbindlich
not binding scheme
ce tableau de mesures reste sans engagement

Technische Änderungen vorbehalten
Technical alterations reserved
Sous reserves de modifications techniques

| | | | | | | |
|--|--|---|---|--|------------------|------------------------|
| FIBRO | | Unberabte Kanten gebrochen Break all sharp corners | Projektion / Projection DIN ISO 128-30 | Gewicht / Weight 20,62 kg | Format DIN A1 | Maßstab / Scale 1:5 |
| BEACHTEN / NOTICE DIN ISO 14601 & 2007-12 ISO 14405-1 | | Urspr. Zeichnung / Source drawing | | Werkstoff / Material | | |
| Allgemeintoleranzen General tolerances DIN ISO 2768 mH | | Datum Date | Name Name | Bezeichnung 1 / Designation 1 FIBROTOR BMZ | | |
| > 6 30 120 400 1000 2000 bis 0,1 0,2 0,3 0,5 0,8 1,2 2,0 | | Bearb. Dr. by | 05.03.2019 Baberske, Michelle | Bezeichnung 2 / Designation 2 EM/ER.12.0220.1.142.XX.0.0.X | | |
| Oberfläche / Surface DIN-ISO 1302 | | FIBRO Rundische GmbH Weidachstrasse 41-43 D-74189 Weinsberg T +49 7134 / 73-0 F +49 7134 / 73-218 | | Zeichen / Sign Rz gemittelt / average | | |
| | | 100 63 25 16 10 4 | | Artikel-Nr. / Article code 4-812-000-3000 | | |
| | | | | Blatt / Sheet 1 von / of 1 Index Rev. 1 | | |

